

Modello a pavimento
Floored model
Modèle au sol
Überflur-Modell

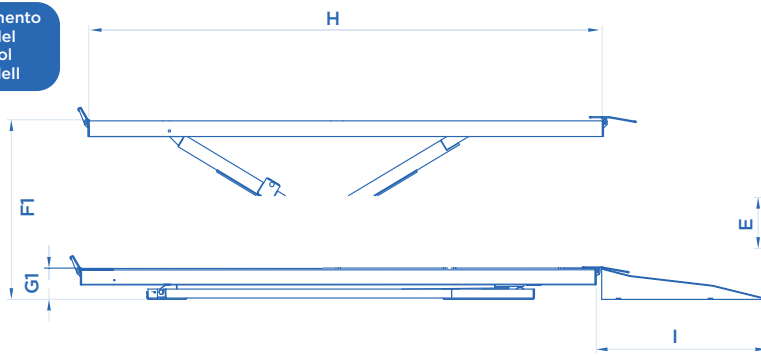

Modello a scomparsa
Disappearing model
Modèle encastrable
Unterflur-Modell

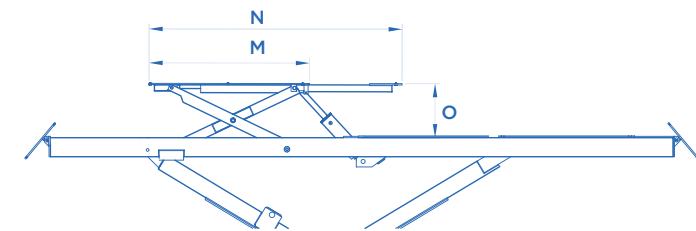
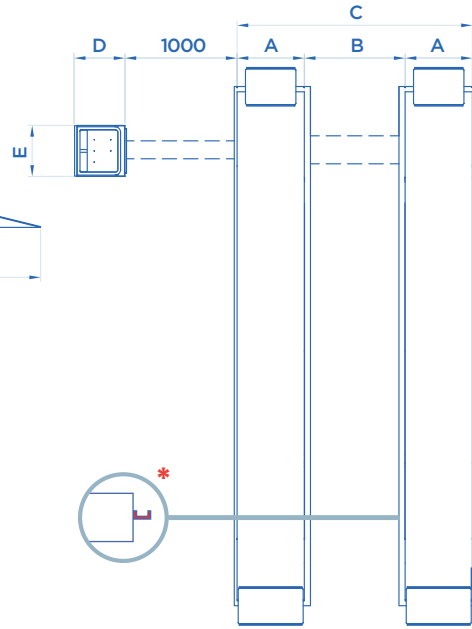
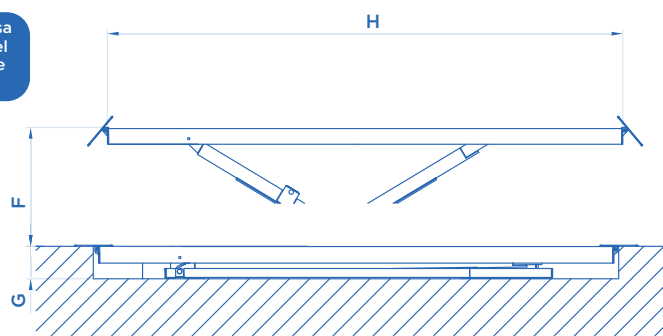

ART. M mm N mm O mm

824 • 824/I	3000 Kg	1420	1870	400
804 • 814	4000 Kg	1465	2000	400

ART.			Motore trifase Three-phase motor Moteur triphasé Netzspannung	A mm	B mm	C mm	D mm	E mm	F mm	F1 mm	G mm	G1 mm	H mm	I mm	KG
835 835/I	3500 Kg	3,3 KW	400V • 50HZ	650 650	900 900	2200 2200	460 460	450 450	1800	1880	290	280	5100 5100	1500	1820 1670
820 820+853/A 820/I 820/I+853/A 824 824+853/A 824/I 824/I+853/A	4000 Kg	3,3 KW	400V • 50HZ	600 600 600 600 600 600 600	900 900 900 900 900 900 900	2100 2100 2100 2100 2100 2100 2100	460 460 460 460 460 460 460	450 450 450 450 450 450 450	1800 1800 1800 1800 1800 1800 1800	1880 1880 1880 1880 1880 1880 1880	290 290 290 290 290 290 290	280 280 280 280 280 280 280	4600 4600 4600 4600 4600 4600 4600	1500 1500 1500 1500 1500 1500 1500	1970 2020 1690 1740 2380 2430 2100 2150
800 800+853/B 810 810+853/B 804 804+853/B 814 814+853/B	5000 Kg	4 KW	400V • 50HZ	650 650 650 650 650 650	900 900 900 900 900 900	2200 2200 2200 2200 2200 2200	500 500 500 500 500 500	550 550 550 550 550 550	1800 1800 1800 1800 1800 1800	1880 1880 1880 1880 1880 1880	290 290 290 290 290 290	280 280 280 280 280 280	4900 4900 4900 4900 4900 4900	1700 1850 1850 1700 1850 1850	2350 2420 2070 2140 2850 2920 2600 2670